

The RMI's Water & Sewer Utilities:
A Review of the MWSC and KAJUR

**RMI Water
Summit
March 22-23,
2011**





Presentation Outline

- Company overviews
- Current systems
- Major challenges
- Priorities and plans
- Ongoing assistance & cooperation
- Critical needs



Company Overviews

- Majuro Water and Sewer Company (MWSC) Inc. incorporated in 1989. Provides collection and distribution of fresh water and waste water on Majuro Atoll.
- Kwajalein Atoll Joint Utilities Resources (KAJUR) Inc. incorporated in 1990. Provides fresh water, waste water and electrical services for Ebeye and Santo islands in Kwajalein Atoll.

Current systems

	MWSC (Majuro)	KAJUR (Ebeye)
Water sources/generation	Airport runway catchment, groundwater wells (Laura/Delap), rooftops (Capital and Hospital).	Reverse-osmosis system (3 r/o units) produce maximum of 350k gallons per day.
Storage systems/capacity	Airport reservoirs (36.5m gal) and smaller Delap reservoir.	Three concrete 250,000 gallon (250K gallon) above ground tanks.
Distribution systems	Reticulated system, around 1,100 hh online (1/3 of total Majuro hh).	Reticulated system on most of Ebeye except northern tip, in 2006 estimated 1,000 hh connected (around 1/3 of all homes).
Wastewater systems	Reticulated system in main town area (5 salt water pumping stations, 7 sewer lift stations). Untreated sewage outfall pipe ocean side Delap.	Reticulated system on most of Ebeye except northern tip, 2 saltwater pumping stations and 4 lift stations.

Majuro Water System

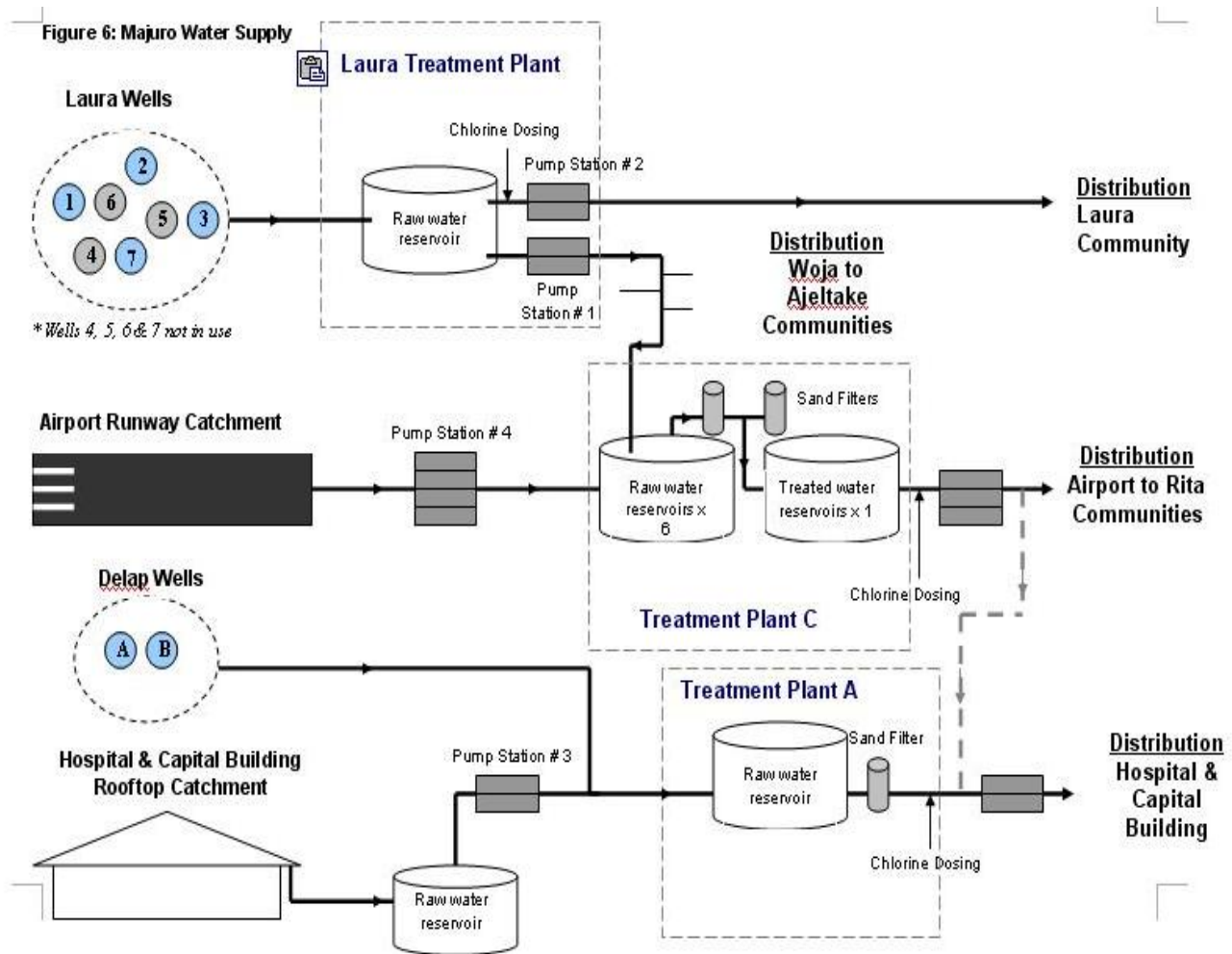

Airport Catchment

- Rainwater harvested from the Airport runway catchment is the largest source of freshwater on Majuro. Using the airport runway as a catchment area (with approximately 80 acres of surface area) the system yields about 223 million gallons annually.



Laura Well-field

- The Laura lens located on the west of Majuro atoll is the second largest source of freshwater on Majuro
- MWSC water-supply wells were designed to collect water from the top of the freshwater lens and thus minimizing the intrusion of saltwater



Delap Wells ,Hospital & Capital Building Rooftop Catchments

- This system consists of 2 wells at Delap, connected with rooftop catchment at the Hospital and Capital building.
- This system services mainly the Hospital, Capital Building and the ICC Building. (24 hour service)



Treatment

- Chlorination
 - Hypochlorite Calcium Powder is used to get rid of all pathogens in the water
- Sand Filtration
 - Used for water purification.

Salt Water System

- With the use of salt water as a mean to flush toilets, it greatly decreases the stress on our limited fresh water resources.
- There are five salt water pump stations throughout Majuro.
 - Salt water pump station #1 - Office
 - Salt water pump station #2 - Hospital
 - Salt water pump station #3 - Uliga Dock
 - Salt water pump station #4 - Rairok
 - Salt water pump station #5 - Plant C



Ebeye Fresh Water System

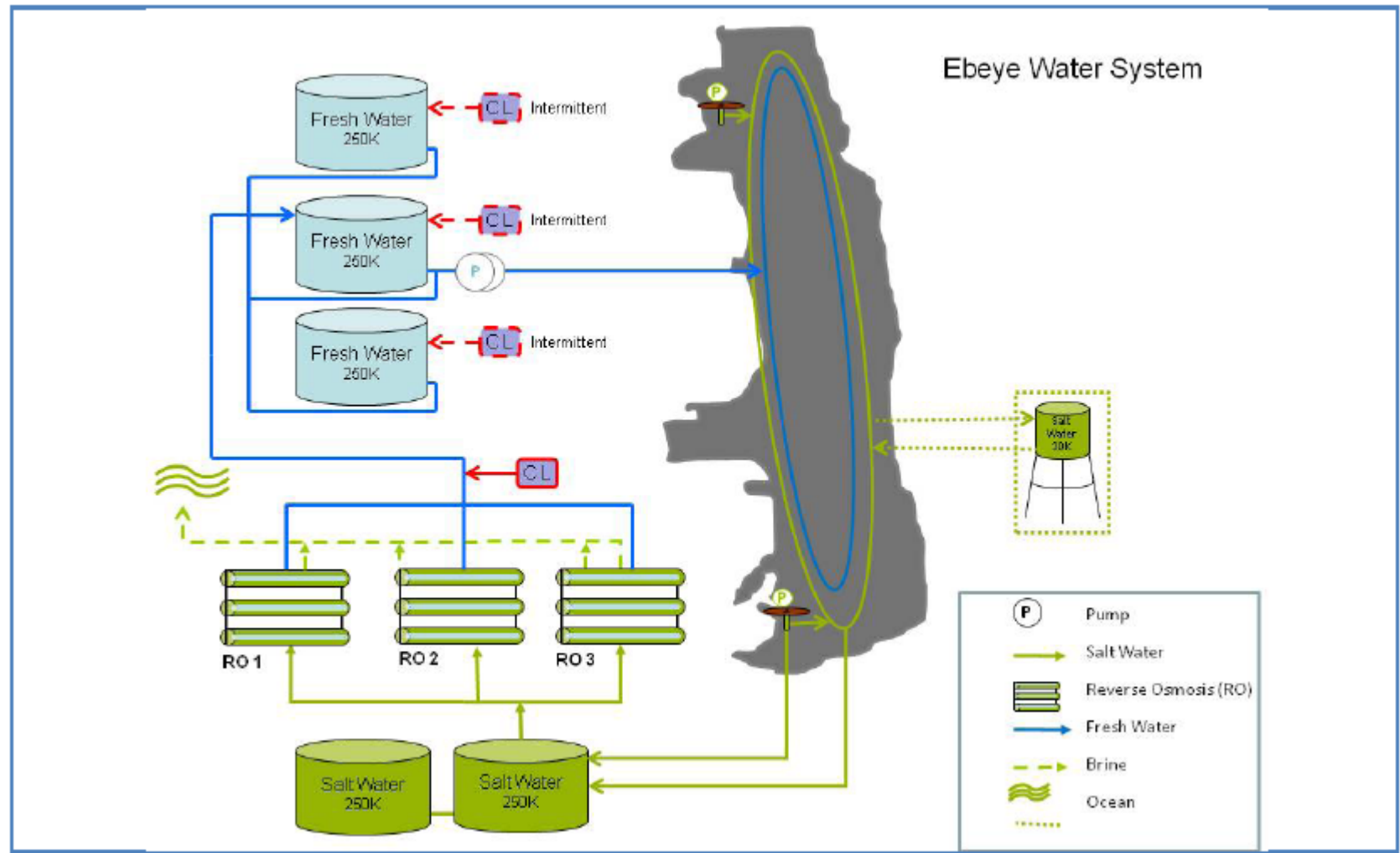

Ebeye Fresh/Salt Water Systems

- ++ Fresh Water Valve
- ++ Salt Water Valve
- Salt Water Hydrant
- Water Pump
- ~ Fresh Water
- ~ Salt Water
- Water Well
- Desalination Plant



Ebeye Sewage System

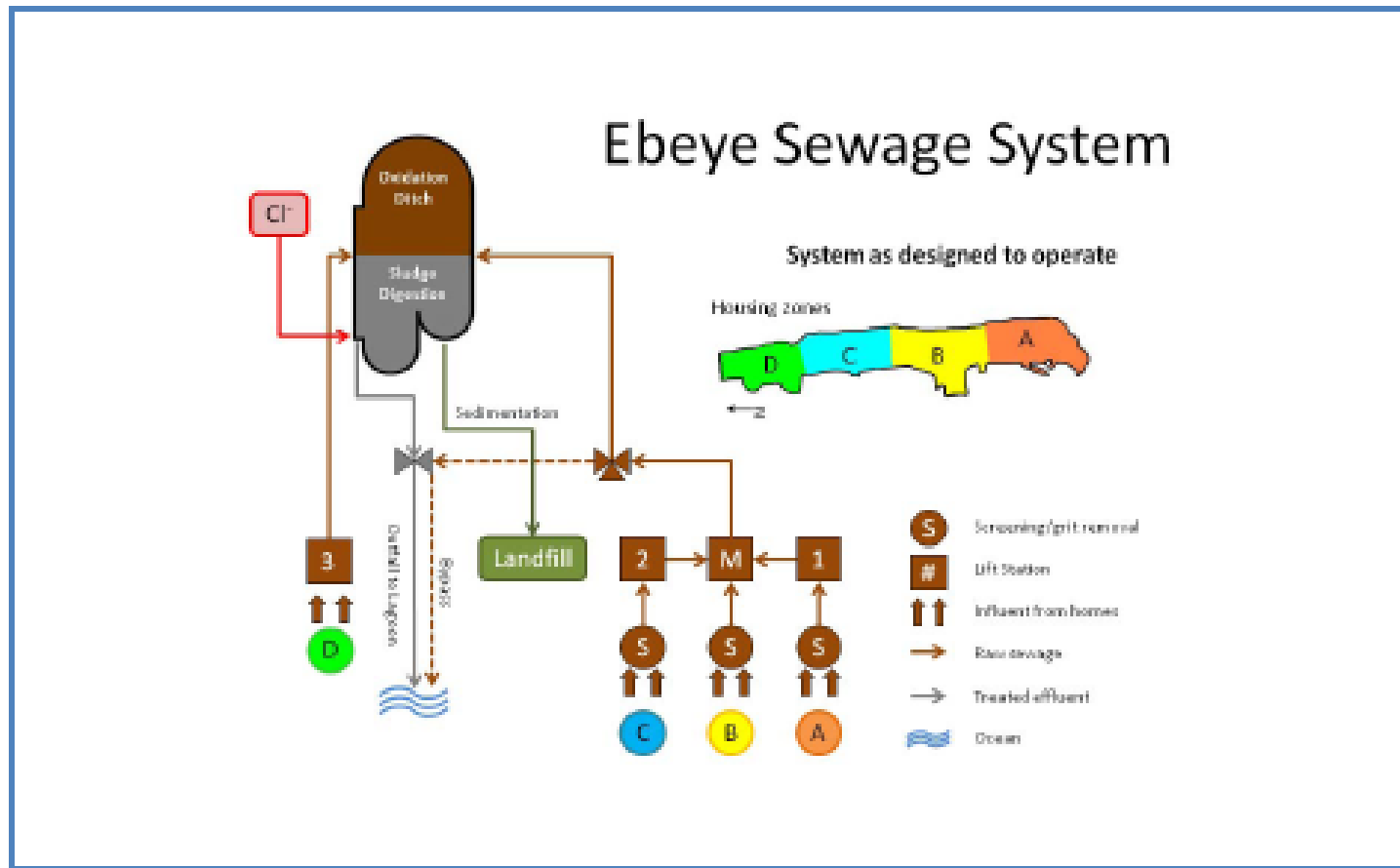

Challenges in MWSC/KAJUR

- Unaccounted water loss
- Deteriorating systems
- Water pollution
- Increasing demand
- Financial hurdles
- Laura – competing uses, unresolved issues
- Climate change impacts
- Problematic wastewater systems



Multiple cracks with air bubbles coming through.

Unaccounted for Water Loss

- Theft and leakage in Majuro's water system very critical. Estimated upwards of 50 percent water loss because of illegal connections and leaks.
- MWSC has recently stepped up its detection efforts, but much more needs to be done, including stiffer penalties for illegal water connections



Deteriorating Systems

- Most of MWSC's main water lines are more than twenty years old.
 - Pipe material consist cast iron pipes, which will cause corrosion which leads to low pressure and high turbidity.
- Both MWSC and KAJUR infrastructure needs major upgrades and modernization
- Relatively little public investment into public water/sewer systems





Water Pollution

- Faecal Contamination
 - Microbial contamination of source water from septic tanks, piggeries, cemeteries, and commercial fertilizers a major threat to the drinking water supply in Majuro.
 - The Hospital and Capital building rooftops could be a reservoir for microbial pathogens from bird and rat waste



Increasing Demand

- As populations grow in Majuro and Ebeye, demand for MWSC's and KAJUR's services will grow, especially during the drought seasons, putting added stress on our limited water resources.
- Commercial demand for water also an important consideration for economic development.

Climate Change Impacts

- Rising Sea Levels
 - Increases the vulnerability of our water wells (Laura & Delap) to salt water intrusion.
 - Sea Water Flooding to our Airport Runway Catchment.

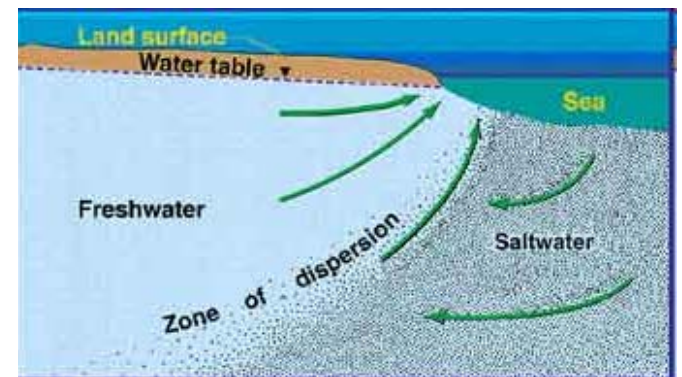



Wastewater collection/disposal

- Both Majuro and Ebeye's waste water collection and disposal systems have serious problems
- Untreated wastewater disposed of into ocean (Majuro) and lagoon (Ebeye)
- Major upgrades required

Financial Hurdles

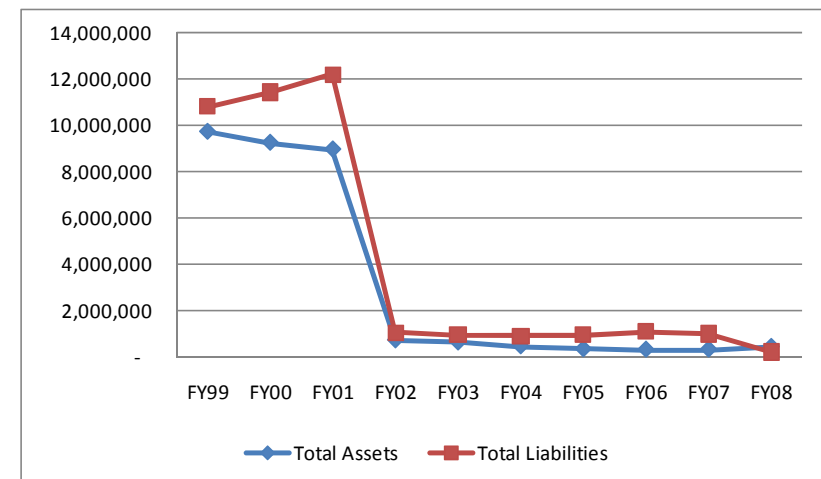
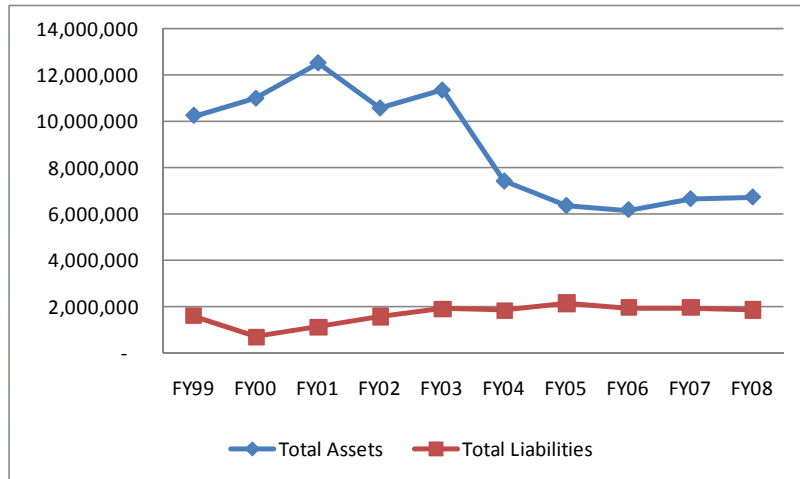
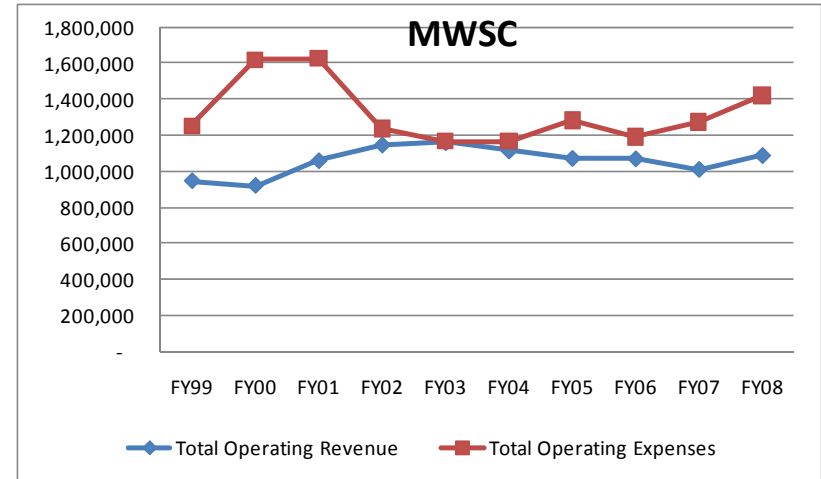
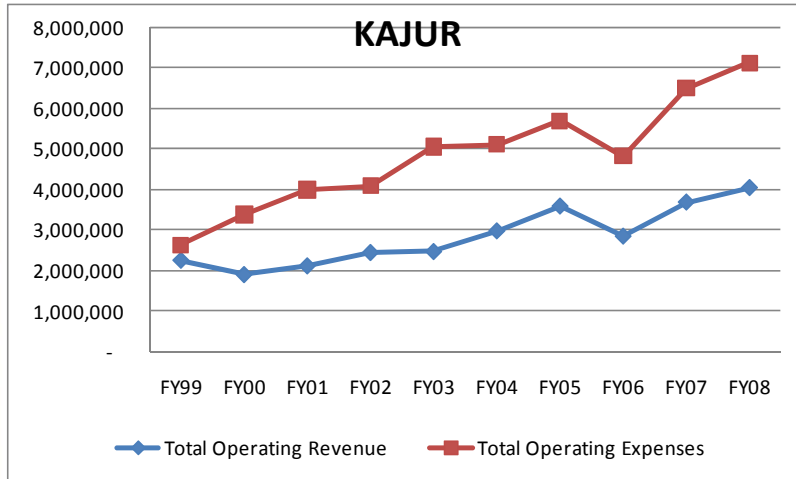

Priorities and Plans

- Re-form Boards for MWSC and KAJUR (appoint qualified professionals to boards)?
- Make major infrastructure upgrades and expansion to water storage systems, water distribution system, saltwater system (including pump stations), and sewer line and outfall systems, etc.
- More training and capacity building for management and staff
- Getting Majuro's Water Safety Plan implemented (to consistently ensure the safety and acceptability of a drinking water supply.) Establish Water Safety Plan for Kwajalein?
- Certification



Priorities and Plans

- Explore concept of “community service obligation” contracts with the Government to provide utilities with clear, predictable support in return for specific services
- Reduce expenses and grow revenues
- Reduction in non-revenue water
- More demand-side awareness activities to encourage more efficient water use and water quality
- Major improvements to wastewater systems

Priorities and Plans

- For Ebeye, Army Corps of Engineers report 2010 identified:

Sewer

1. Bring the sewage treatment plant to an operational status and upgrade to meet U.S. EPA effluent standards.
2. Clear the existing drainage structures of sand and debris to bring to an operational status.
3. Replace pumps and controls in the sewage lift stations.

Water

1. Increase salt water production to supply adequate feed water for fresh water production and increase line pressure.
2. Increase fresh water production and line pressure to meet current population demand (15,000 PN).
3. Install salt and fresh water distribution system at north end of island.

Ongoing Assistance

- European Union's donation of two trucks (water truck & septic vacuum truck)
- Federal Aviation Administration's help with a distribution pump and a drainage cleaner. (all used for the runway catchments)
- ADB Technical Assistance to help MWSC and KAJUE develop reform plans
- ADB Technical Assistance for climate change impacts to MWSC

Ongoing Assistance

- Solar Panels for Laura Wells, with the help of Energy Taskforce at R&D
- Water Engineer through AusAID.
- Getting equipment/materials to prevent leakage and evaporation from SEA-PACC
- US Army Corps of Engineers survey of Ebeye infrastructure
- More assistance needed in several areas

Komol tata